



CSP MOSFET 数据手册

NP12045ECA-X

CSP 12V Typ 4.5mΩ Dual N-Channel MOSFET

Rev. 1.0 Version

请注意以下有关宁波宝芯源功率半导体有限公司知识产权政策

* 宁波宝芯源功率半导体有限公司（以下简称本公司）已申请了专利，享有绝对的合法权益。与本公司产品有关的专利权并未被同意授权使用，任何经由不当手段侵害本公司专利权的公司、组织或个人，本公司将采取一切可能的法律行动，遏止侵权者不当的侵权行为，并追讨本公司因侵权行为所受的损失、或侵权者所得的不法利益。

* 宁波宝芯源功率半导体有限公司的名称和标识都是本公司的注册商标。

* 本公司保留对规格书中产品在可靠性、功能和设计方面的改进作进一步说明的权利。然而本公司对于规格内容的使用不负责任。文中提到的应用其目的仅仅是用来做说明，本公司不保证和不表示这些应用没有更深入的修改就能适用，也不推荐它的产品使用在会由于故障或其它原因可能会对人身造成危害的地方。本公司的产品不授权适用于救生、维生器件或系统中作为关键器件。本公司拥有不事先通知而修改产品的权利，对于最新的信息，请参考官方网站 www.pwcore.com。

最大额定值 Maximum Ratings^①

参数 Parameter	符号 Symbol	数值 Value	单位 Unit
源极-源极击穿电压 Source-Source Breakdown Voltage	BV_{SSS}	12	V
栅极-源极电压 Gate to Source Voltage	V_{GS}	± 10	V
直流源极电流 Source Current (DC)	I_S	9.0	A
脉冲源电极电流 Source Current (Pulse) $PW \leq 10\mu s, Duty\ Cycle \leq 1\%$	I_{Sp}	90	A
耗散功率 Power Dissipation	P_D	0.5	W
结温 Operating Junction Temperature	T_J	-55...+150	$^{\circ}C$
存储温度 Storage Temperature	T_{Stg}	-55...+150	$^{\circ}C$

① 超过最大额定值表中列出的使用条件可能会损坏芯片。如果超过这些限制值中的任何一个，则芯片的功能可能无法保证，芯片可能发生损坏并影响可靠性。

Stresses exceeding those listed in the Maximum Ratings table may damage the device. If any of these limits are exceeded, device functionality should not be assumed, damage may occur and reliability may be affected.

热阻特性 Thermal Resistance^②

参数 Parameter	符号 Symbol	数值 (最大) Max. Value	单位 Unit
结到环境热阻 Thermal Resistance Junction to Ambient	$R_{\theta JA}$	250	$^{\circ}C/W$

② 芯片表面贴于 70mmX70mm 环氧树脂 PCB 板。

Surface mounted on Mounted on 70mmx70mm FR4 board

电气特性 Electrical Characteristics ($T_j = 25^\circ\text{C}$ unless otherwise noted)

项目③ Parameter	符号 Symbol	测试条件 Conditions	数值 Value			单位 Unit
			Min.	Typ.	Max.	
源极-源极击穿电压 Source to Source Breakdown Voltage	$V_{(BR)SSS}$	$I_s = 1 \text{ mA}$, $V_{GS} = 0 \text{ V}$ Test Circuit 1	12	-	-	V
零栅压下源极漏电流 Zero Gate Voltage Source Current	I_{SSS}	$V_{SS} = 10 \text{ V}$, $V_{GS} = 0 \text{ V}$ Test Circuit 1	-	-	1.0	μA
栅极-源极漏电流 Gate to Source Leakage Current	I_{GSS1}	$V_{GS} = \pm 5 \text{ V}$, $V_{SS} = 0 \text{ V}$ Test Circuit 2	-	-	± 1.5	μA
栅极-源极漏电流 Gate to Source Leakage Current	I_{GSS2}	$V_{GS} = \pm 8 \text{ V}$, $V_{SS} = 0 \text{ V}$ Test Circuit 2	-	-	± 10	μA
阈值电压 Gate Threshold Voltage	$V_{GS(th)}$	$V_{SS} = 6 \text{ V}$, $I_s = 1 \text{ mA}$ Test Circuit 3	0.4	-	1.0	V
源极到源极直流导通电阻 Static Source to Source On-State Resistance	$R_{SS(on)}$	$I_s = 5 \text{ A}$, $V_{GS} = 4.5 \text{ V}$ Test Circuit 4	1.6	4.5	5.9	$\text{m}\Omega$
		$I_s = 5 \text{ A}$, $V_{GS} = 3.8 \text{ V}$ Test Circuit 4	1.7	5.4	7.5	$\text{m}\Omega$
		$I_s = 5 \text{ A}$, $V_{GS} = 3.1 \text{ V}$ Test Circuit 4	1.8	6.1	8.0	$\text{m}\Omega$
		$I_s = 5 \text{ A}$, $V_{GS} = 2.5 \text{ V}$ Test Circuit 4	2	7.2	10.0	$\text{m}\Omega$
源极到源极正向压降 Forward Source to Source Voltage	$V_{F(S-S)}$	$I_s = 1 \text{ A}$, $V_{GS} = 0$ Test Circuit 7	0.4	0.62	1.0	V

③ 产品的参数性能按照上述表格参数所描述，除非有额外的说明。如果产品工作在其他不同的条件下，产品的电学性能可能并不遵守上述参数。

Product parametric performance is indicated in the Electrical Characteristics for the listed test conditions, unless otherwise noted. Product performance may not be indicated by the Electrical Characteristics if operated under different conditions.

测试电路范例 Test Circuits Example

Test Circuit 1
VSSS / ISSS

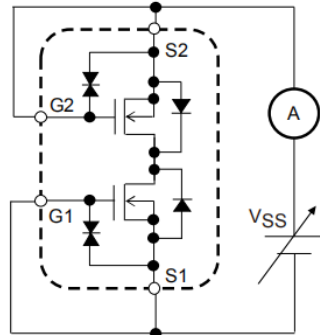

Test Circuit 2
IGSS

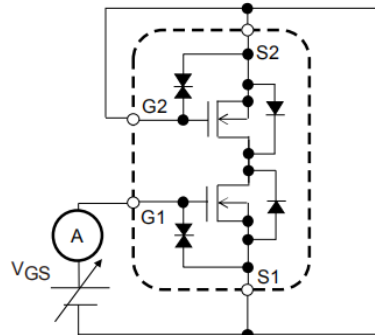

When FET1 is measured, Gate and Source of FET2 are short-circuited.

Test Circuit 3
VGS(th)

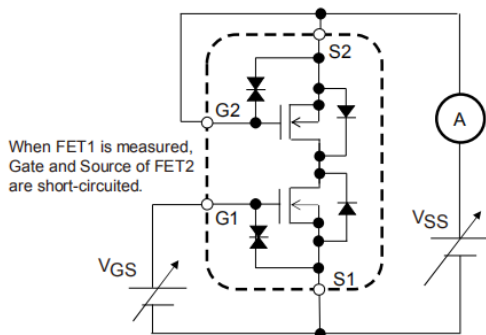

Test Circuit 4
RSS(on)

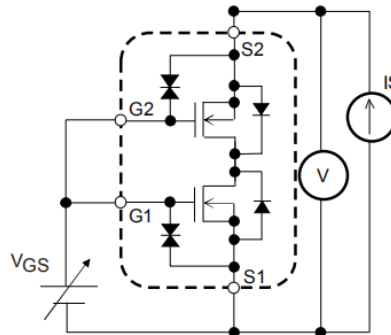

Test Circuit 5
 $t_d(on)$, t_r , $t_d(off)$, t_f

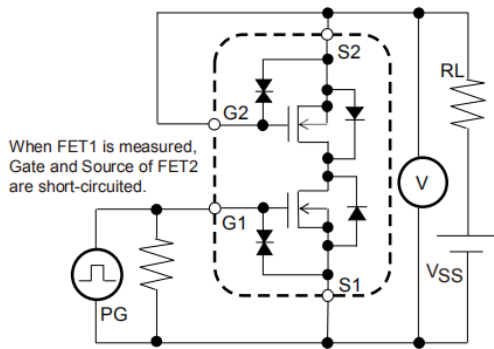

Test Circuit 6
Qg

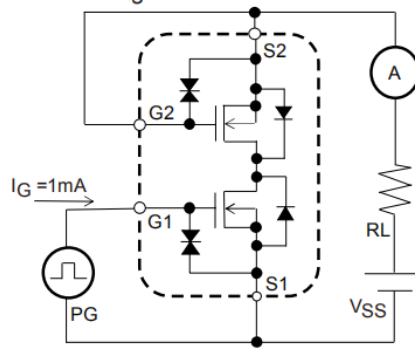

Test Circuit 7
VF(S-S)

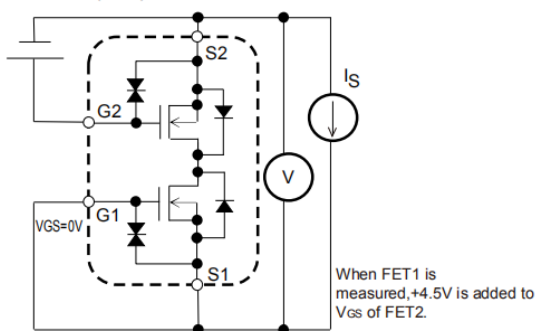

特征电学和温度曲线 Typical Electrical and Thermal Characteristics

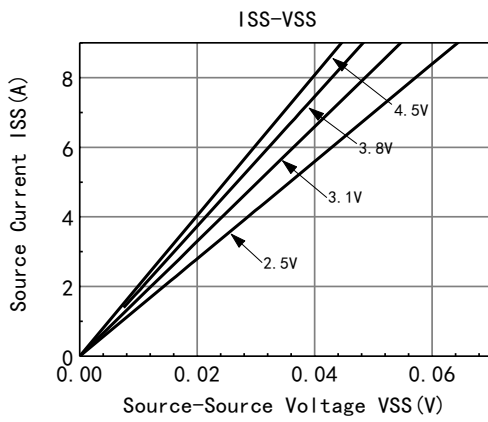

Figure 1: On-Region Characteristics

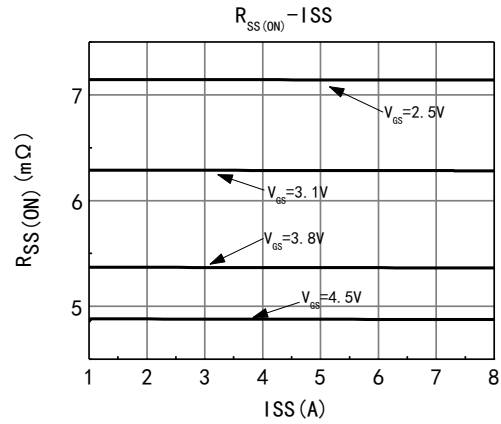

Figure 2: On-Resistance vs. Source Current and Gate Voltage

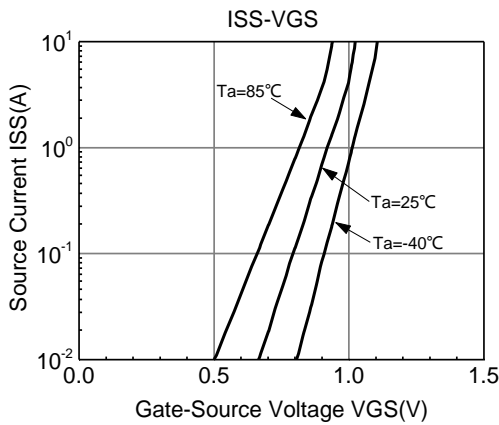

Figure 3: Typical Transfer Characteristics

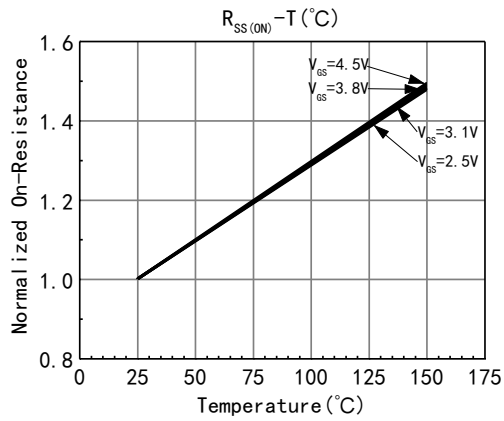

Figure 4: On-Resistance vs. Junction Temperature

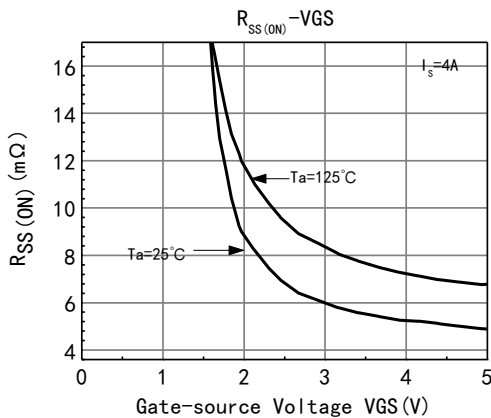

Figure 5: On-Resistance vs. Gate-Source Voltage

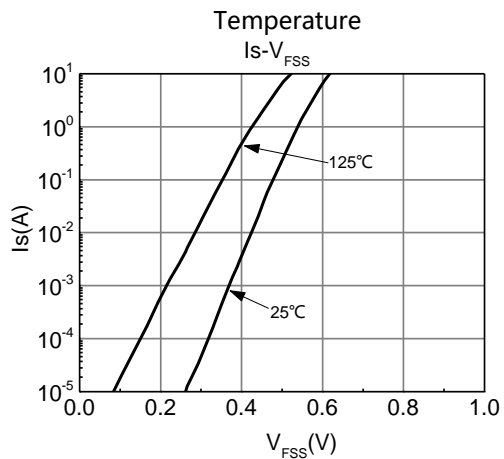

Figure 6: Forward Source to Source Characteristics

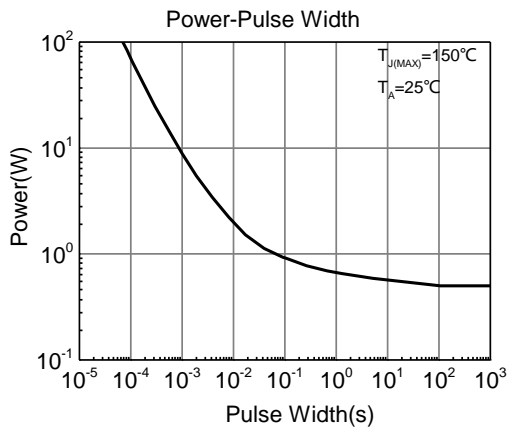

Figure 7: Single Pulse Power Rating Junction to Ambient

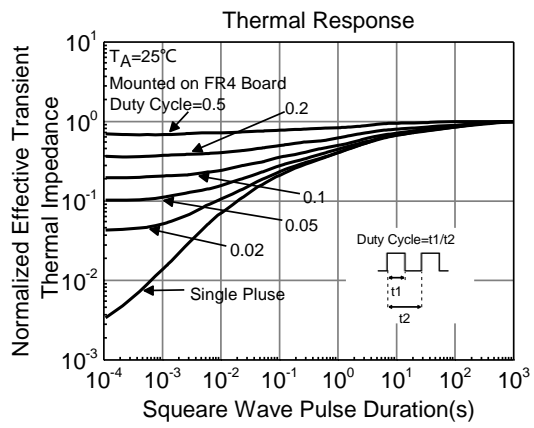

Figure 8: Normalized Maximum Transient Thermal Impedance

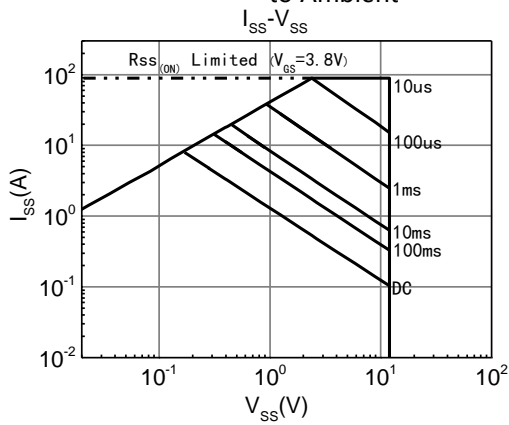
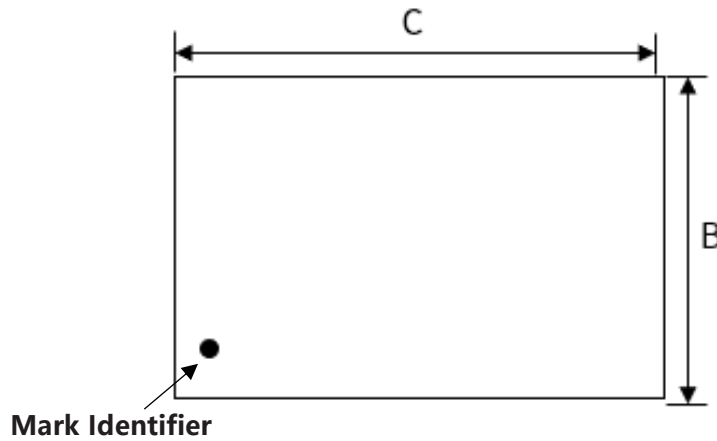

Figure 9: Safe Operating Area

封装尺寸 Package Dimensions:

Top View



Side View



Bottom View

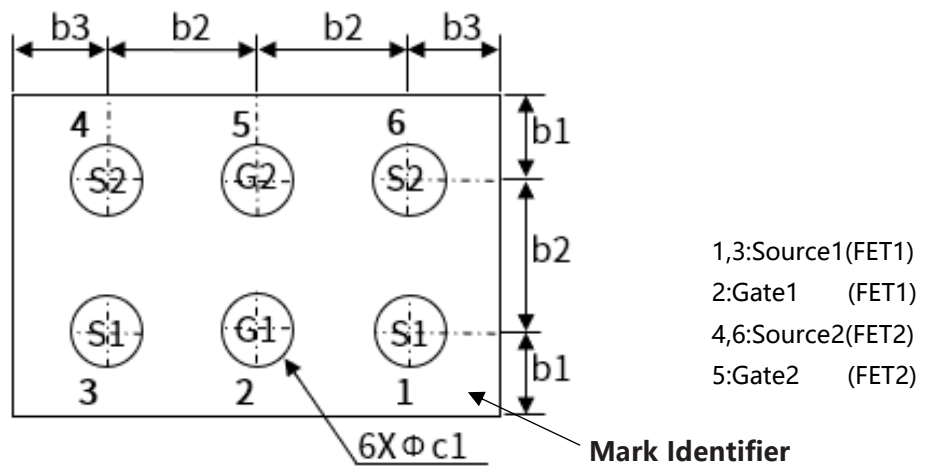

Symbol	Dimensions In Millimeters			Dimensions In Inches		
	Min.	Typ.	Max.	Min.	Typ.	Max.
A	0.27	0.30	0.33	0.0106	0.0118	0.0130
B	1.35	1.40	1.45	0.0531	0.0551	0.0571
C	2.08	2.14	2.20	0.0819	0.0843	0.0866
b1	0.335	0.375	0.415	0.0132	0.0148	0.0163
b2	0.61	0.65	0.69	0.0240	0.0256	0.0272
b3	0.38	0.42	0.46	0.0150	0.0165	0.0181
c1	0.27	0.30	0.33	0.0106	0.0118	0.0130

历史版本 Version history

版本号	时间	修改内容
V1.0	2024 年 03 月	初始版本