



IGBT 数据手册

NP020G060T63B/T2FA

600V 20A Trench Gate + Field Stop IGBT

Rev. 1.0

请注意以下有关知识产权政策

*宁波宝芯源功率半导体有限公司（以下简称本公司）已申请了专利，享有绝对的合法权益。与本公司产品有关的专利权并未被同意授权使用，任何经由不当手段侵害本公司专利权的公司、组织或个人，本公司将采取一切可能的法律行动，遏止侵权者不当的侵权行为，并追讨本公司因侵权行为所受的损失、或侵权者所得的不法利益。

*宁波宝芯源功率半导体有限公司的名称和标识都是本公司的注册商标。

*本公司保留对规格书中产品在可靠性、功能和设计方面的改进作进一步说明的权利。然而本公司对于规格内容的使用不负责任。文中提到的应用其目的仅仅是用来做说明，本公司不保证和不表示这些应用没有更深入的修改就能适用，也不推荐它的产品使用在会由于故障或其它原因可能会对人身造成危害的地方。本公司的产品不授权适用于救生、维生器件或系统中作为关键器件。本公司拥有不事先通知而修改产品的权利，对于最新的信息，请参考官方网站www.pwcore.com。

IGBT 600V/20A NP020G060T63B/T2FA

产品特性 Features

- | | |
|-------------------|--|
| ◆ 沟槽栅场截止工艺技术 | Trench Gate and Field Stop Processes IGBT |
| ◆ 低饱和压降和高开关速度 | Low $V_{CE(sat)}$ and High Switching Speed |
| ◆ 饱和压降呈正温度特性 | Positive $V_{CE(sat)}$ Temperature Coefficient |
| ◆ 10 μ s 短路能力 | 10 μ s of Short-Circuit Withstand Time |
| ◆ 并联封装快恢复二极管 | Soft and Fast Recovery Antiparallel Diode |
| ◆ 无铅引脚符合 RoHS 要求 | Pb-free Lead Plating, RoHS Compliant |

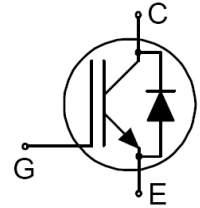

应用领域 Applications

- | | |
|-------------|-----------------------------|
| ◆ 冰箱, 油烟机 | Refrigerator and Range Hood |
| ◆ 小功率风机, 水泵 | Fan Motor and Water Pump |

关键参数与封装信息 Key Performance and Package Parameters

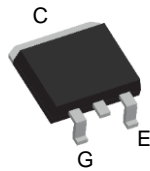

TO-263

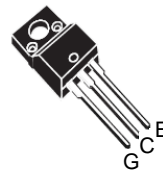

TO-220F

产品型号 Part No.	封装 Package	集电极-发射极电压 V_{CE}	集电极电流 I_C	饱和压降 V_{CEsat}	二极管压降 V_F	印记 Marking
NP020G060T63B	TO-263	600V	20A	1.5V	1.6V	NP020G060C
NP020G060T2FA	TO-220F					NP020G060D

最大额定值 Maximum Ratings

参数 Parameter	符号 Symbol	数值 Value	单位 Unit
集电极-发射极直流电压 Collector-Emitter Voltage	V _{CE}	600	V
栅极-发射极电压 Gate-Emitter Voltage	V _{GE}	±30	V
直流集电极电流, 由最高结温限制 DC Collector Current, Limited by T _{vjmax} T _C = 25°C T _C = 100°C	I _C	40 20	A
脉冲集电极电流① Pulsed Collector Current	I _{CM}	60	A
安全工作区 Turn Off Safe Operating Area V _{CE} ≤ 600V, T _J ≤ 150°C, t _p = 1μs		60	A
二极管正向电流 Diode Forward Current T _C = 25°C T _C = 100°C	I _F	40 20	A
耗散功率(TO-263 / TO-220F) Power Dissipation(TO-263 / TO-220F) T _C = 25°C T _C = 100°C	P _D	138 55	W
结温 Operating Junction Temperature	T _J	-40...+150	°C
存储温度 Storage Temperature	T _{stg}	-55...+150	°C
最高焊接温度 Maximum Soldering Temperature		260	°C

① 脉冲宽度由最高结温限制 Pulse width limited by maximum junction temperature

热阻特性 Thermal Resistance

参数 Parameter	符号 Symbol	数值 (最大) Max. Value	单位 Unit
结到管壳热阻 (TO-263 / TO-220F) Thermal Resistance Junction to Case (TO-263 / TO-220F)	R _{θJC}	0.9 / 0.9	°C / W
结到环境热阻 (TO-263 / TO-220F) Thermal Resistance Junction to Ambient (TO-263 / TO-220F)	R _{θJA}	40 / 78	°C / W

电气特性 Electrical Characteristics ($T_J = 25^\circ\text{C}$ unless otherwise noted)

项目 Parameter	符号 Symbol	测试条件 Conditions	数值 Value			单位 Unit	
			Min.	Typ.	Max.		
集电极-发射极击穿电压 Collector-Emitter Breakdown Voltage	$V_{(BR)CES}$	$V_{GE}=0V, I_C=1mA$	600	-	-	V	
集电极-发射极饱和压降 Collector-Emitter Saturation Voltage	V_{CEsat}	$V_{GE}=15V, I_C=20A$ $T_J=25^\circ\text{C}$ $T_J=150^\circ\text{C}$	-	1.5 1.6	2	V	
阈值电压 Gate-Emitter Threshold Voltage	$V_{GE(th)}$	$V_{CE}=V_{GE}, I_C=1mA$	4.5	-	6.5	V	
二极管正向压降 Diode Forward Voltage	V_F	$I_F=20A$	-	1.6	2.1	V	
零栅压下集电极漏电流 Zero Gate Voltage Collector Current	I_{CES}	$V_{CE}=600V, V_{GE}=0V$ $T_J=25^\circ\text{C}$ $T_J=150^\circ\text{C}$	-	-	1 100	μA	
栅极发射极漏电流 Gate-Emitter Leakage Current	I_{GES}	$V_{CE}=0V, V_{GE}=30V$	-	-	200	nA	
输入电容 Input Capacitance	C_{ies}	$V_{CE}=25V$ $V_{GE}=0V$ $f=1MHz$	-	1140	-	pF	
输出电容 Output Capacitance	C_{oes}		-	50	-		
反向传输电容 Reverse Transfer Capacitance	C_{res}		-	12	-		
栅极电荷总量 Total Gate Charge	Q_g	$V_{CC}=480V$ $I_C=20A$ $V_{GE}=15V$	-	39	-	nC	
栅极-发射极电荷 Gate-Emitter Charge	Q_{ge}		-	8	-		
栅极-集电极电荷 Gate-Collector Charge	Q_{gc}		-	14.5	-		
开启延迟时间 Turn-On Delay Time	$t_{d(on)}$	$T_J=25^\circ\text{C}$ $V_{CC}=400V$ $I_C=20A$ $V_{GE}=15V$ $R_{G(on)}=R_{G(off)}=10\Omega$	-	38	-	ns	
上升时间 Rise Time	t_r		-	48	-		
关断延迟时间 Turn-Off Delay Time	$t_{d(off)}$		-	70	-		
下降时间 Fall Time	t_f		-	76	-		
开通损耗 Turn-On Switching Loss	E_{on}		-	0.42	-		mJ
关断损耗 Turn-Off Switching Loss	E_{off}		-	0.4	-		mJ

项目 Parameter	符号 Symbol	测试条件 Conditions	数值 Value			单位 Unit
			Min.	Typ.	Max.	
反向恢复时间 Reverse Recovery Time	T_{rr}	$I_F=20A, di/dt=400A/\mu s$	-	58	-	ns
二极管反向恢复峰值电流 Diode Peak Reverse Recovery Current	I_{RRM}		-	9	-	A
反向恢复电荷 Reverse Recovery Charge	Q_{rr}		-	0.3	-	μC

特征曲线 Characteristic Curve

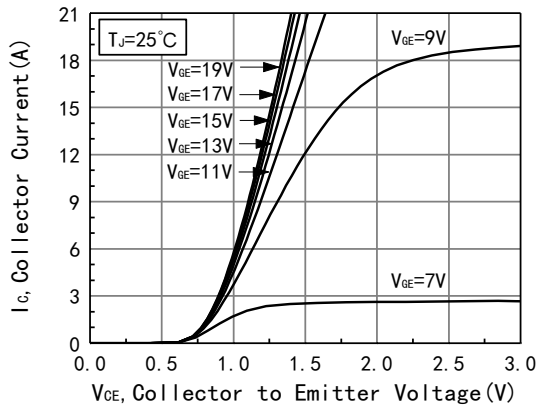

Figure 1. Typical Output Characteristics

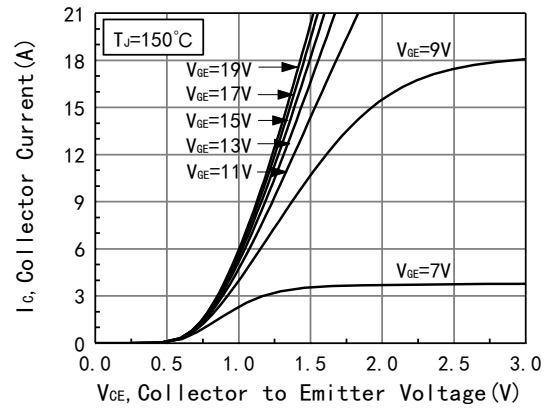

Figure 2. Typical Output Characteristics

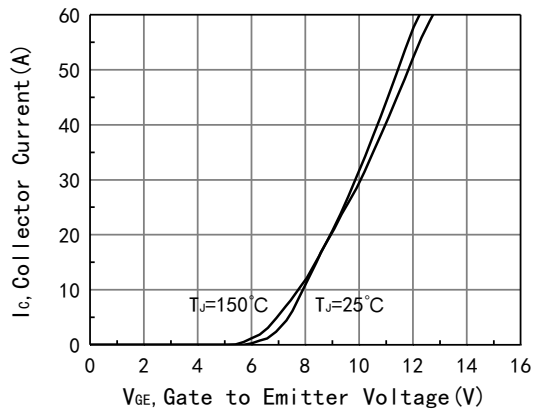

Figure 3. Typical Transfer Characteristics

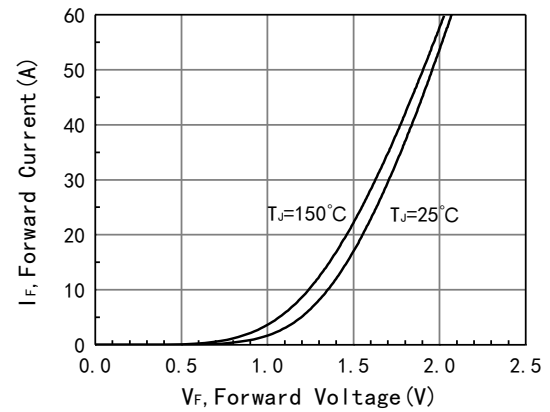

Figure 4. Typical Diode Forward Characteristics

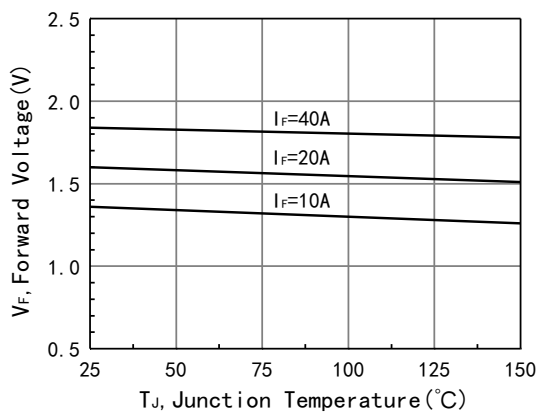

Figure 5. V_F vs. T_J

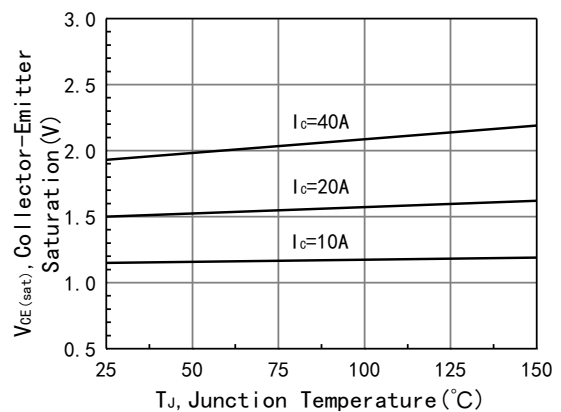

Figure 6. Typical $V_{CE(sat)}$ vs. T_J

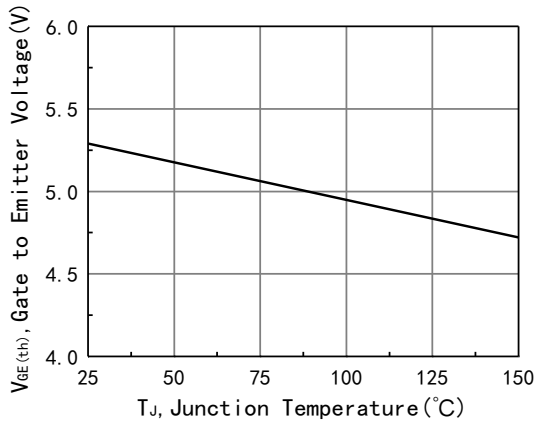

Figure 7. $V_{GE(th)}$ vs. T_J

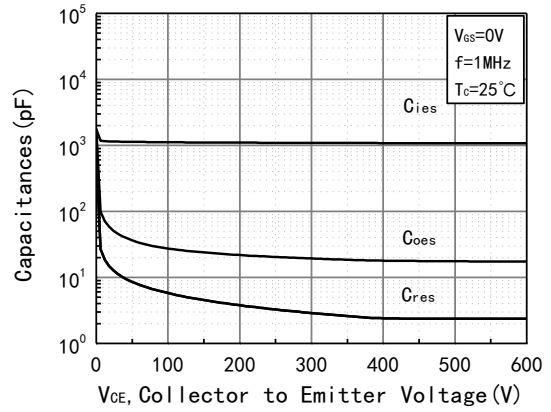

Figure 8. Capacitance vs. V_{CE}

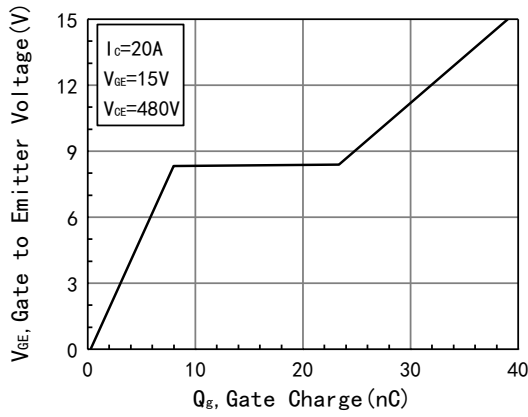

Figure 9. Gate Charge Characteristic

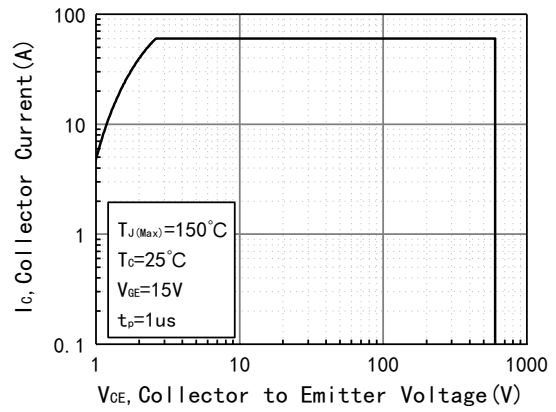

Figure 10. Safe Operating Area

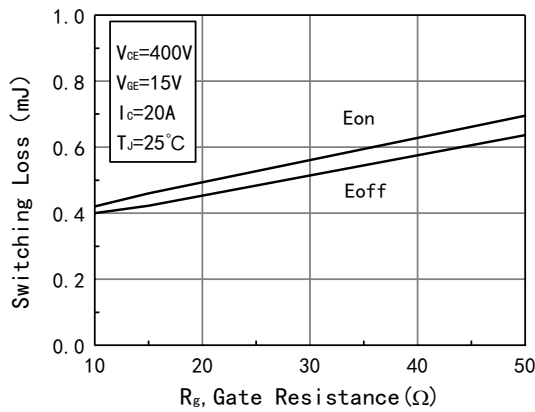

Figure 11. Switching Loss vs. Gate Resistances

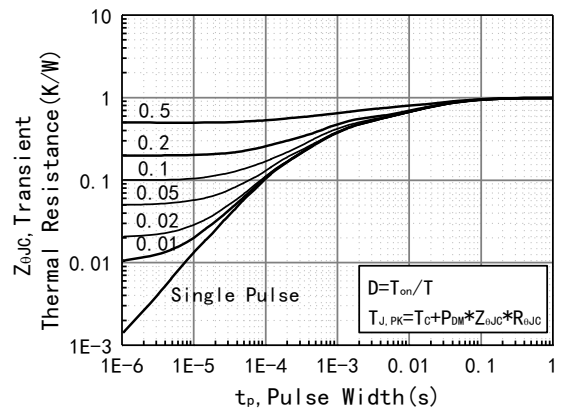
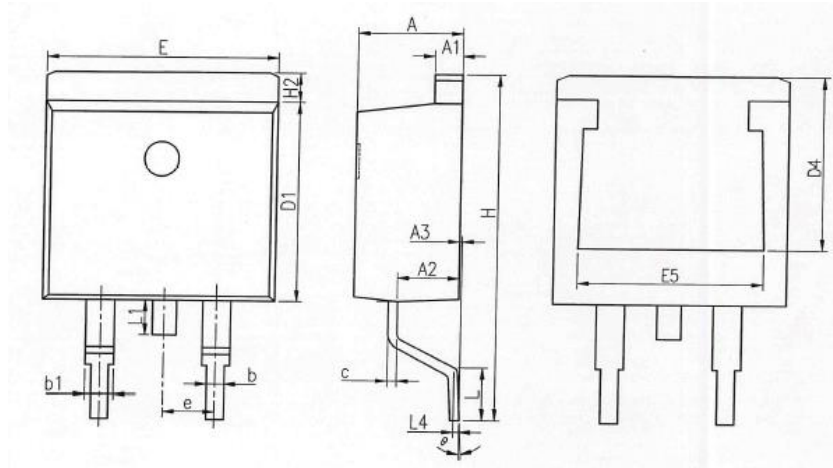

Figure 12. Transient Thermal Resistances

Notes:

Pulse Test: Pulse Width $\leq 380\mu s$, Pulse Delay $\leq 200\mu s$.

外形尺寸 Mechanical Data: TO-263



Dimensions In Millimeterer			
Symbol	MIN	TYP	MAX
A	4.37	4.57	4.77
A1	1.22	1.27	1.42
A2	2.49	2.69	2.89
A3	0.00	0.13	0.25
b	0.70	0.81	0.96
b1	1.17	1.27	1.47
c	0.30	0.38	0.53
D1	8.50	8.70	8.90
D4	6.60	-	-
E	9.86	10.16	10.36
E5	7.06	-	-
e	2.54 BSC		
H	14.70	15.10	15.50
H2	1.07	1.27	1.47
L	2.00	2.30	2.60
L1	1.40	1.55	1.70
L4	0.25 BSC		
θ	0°	5°	9°

外形尺寸 Mechanical Data: TO-220F

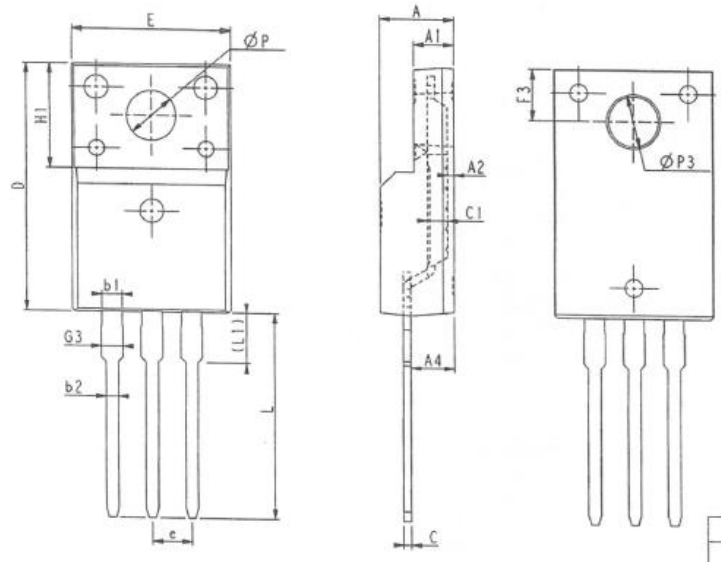

Dimensions In Millimeterer			
Symbol	MIN	TYP	MAX
E	9.96	10.16	10.36
A	4.50	4.70	4.90
A1	2.34	2.54	2.74
A2	0.30	0.45	0.60
A4	2.56	2.76	2.96
c	0.40	0.50	0.60
c1	1.20	1.30	1.35
D	15.57	15.87	16.13
H1	6.48	6.70	6.90
e	2.54BSC		
L	12.68	12.98	13.28
L1	3.03	3.23	3.43
ΦP	3.03	3.18	3.38
$\Phi P3$	3.15	3.45	3.65
F3	3.15	3.30	3.45
G3	1.25	1.35	1.47
b1	1.18	1.28	1.43
b2	0.70	0.80	0.91

历史版本

版本号	时间	修改内容
V1.0	2023年6月	初始版本